



**WITTENSTEIN**

motion control

**TPM<sup>+</sup>**

**Danaher Motion Servostar 400**

**Quick Startup Guide**

# 1 Table of Contents

<b>1</b>	<b>Table of Contents</b>	<b>2</b>
<b>2</b>	<b>General Information</b>	<b>4</b>
2.1	Description, designations	4
2.2	Whom does this manual concern?	4
2.3	Which signs and symbols are referred to in this manual?	4
2.4	Exclusion of liability	4
2.5	EC low-voltage directive / EMC regulations	4
2.6	Copyright	4
<b>3</b>	<b>Safety</b>	<b>5</b>
3.1	Intended use	5
3.2	Improper use	5
3.3	Safety Instructions	5
3.3.1	General safety instructions	5
<b>4</b>	<b>Type plate information – identification</b>	<b>7</b>
4.1	Identification plate, designation	7
<b>5</b>	<b>Setting the parameters</b>	<b>8</b>
5.1	Adjustment of the current controller	8
5.2	Selection of the motorfeedback, brake and commutation offset	8
5.3	TPM <sup>+</sup> 560 V Ratio 16	9
5.4	TPM <sup>+</sup> 560 V Ratio 21	10
5.5	TPM <sup>+</sup> 560 V Ratio 31	11
5.6	TPM <sup>+</sup> 560 V Ratio 61	12
5.7	TPM <sup>+</sup> 560 V Ratio 64	13
5.8	TPM <sup>+</sup> 560 V Ratio 91	14
5.9	TPM <sup>+</sup> 320 V Ratio 16	15
5.10	TPM <sup>+</sup> 320 V Ratio 21	16
5.11	TPM <sup>+</sup> 320 V Ratio 31	17
5.12	TPM <sup>+</sup> 320 V Ratio 61	18
5.13	TPM <sup>+</sup> 320 V Ratio 64	19
5.14	TPM <sup>+</sup> 320 V Ratio 91	20
<b>6</b>	<b>Connection schematic TPM<sup>+</sup></b>	<b>21</b>
6.1	TPM <sup>+</sup> with resolver	21
6.2	TPM <sup>+</sup> with absolute encoder Heidenhain EnDat ECN1113 / EQN 1125	22
6.3	TPM <sup>+</sup> with absolute encoder Sick-Stegmann SKS36 / SKM36	22

**Modification History**

Document designation	Revision	Date	Note
4091-D015933-01.doc	1	23. Oct. 2007	First Edition
4091-D015933-02.doc	2	07. Oct. 2007	Adaption of Corporate Design

**Service**

In case you have technical questions,  
please contact:

**WITTENSTEIN motion control GmbH**

Customer Service

Walter-Wittenstein-Straße 1

D-97999 Igersheim

Tel.: +49 (0) 79 31 / 4 93- 10900

Fax: +49 (0) 79 31 / 4 93- 10903

Email: [service-wmc@wittenstein.de](mailto:service-wmc@wittenstein.de)

**© WITTENSTEIN motion control GmbH 2008**

This documentation is copyright protected.

WITTENSTEIN motion control GmbH reserves all the rights to photo-mechanical reproduction, copying, and the distribution by special processes (such as computers, file media, data networks), even in parts. Subject to technical and content changes without notice.

## 2 General Information

### 2.1 Description, designations

The AC servo actuator **TPM<sup>+</sup>** (hereafter referred to as servo actuator) is a combination of a low-backlash planetary gearhead and an AC servo motor.

The following manual contains the following points:

- Safety Instructions
- Parameter lists for the **TPM<sup>+</sup>** series
- Connection schematic for **TPM<sup>+</sup>**

### 2.2 Whom does this manual concern?

This manual concerns all persons who install, operate, or maintain this servo actuator.

They may only carry out work on the servo actuator, if they have read and understood this operating manual. Please pass the safety instructions on to other persons as well.

### 2.3 Which signs and symbols are referred to in this manual?

➔ An “action instruction”, which requires you to carry out an action.

▽ With a “check” you can specify whether the device is ready for the next work stage.

☺ A “usage tip” shows you an option of facilitating or improving operations.

The safety instructions symbols are described in section [3 “Safety”](#).

### 2.4 Exclusion of liability

**WITTENSTEIN motion control** is not liable for damages or injury caused by:

- Improper utilization of the servo actuator and the servo amplifier or
- Incorrect setting of operating parameters.

### 2.5 EC low-voltage directive / EMC regulations

The servo actuator has been constructed in accordance with EC directive 73/23/EEC.

During installation and connection of the electrical components, the relevant regulations have to be observed (for example wire cross sections, fuse protection, etc.).

Meeting all requirements for the entire system is the responsibility of the system's manufacturer.

You may only operate the equipment if you comply to the national EMC regulations (refer to the servo amplifier documentation for installation information pertaining to EMC) as they are defined for the given application.

### 2.6 Copyright

© 2008, **WITTENSTEIN motion control** GmbH

All of the product brand names which appear in this manual are trademarks of the relevant companies. If the ® and/or <sup>TM</sup> symbols are omitted, this does imply that the name is a free brand name.

## 3 Safety

### 3.1 Intended use

The servo actuator is designed for industrial applications. Its purpose is to drive machines. Please refer to our catalogue or our Internet page for the maximum permitted speeds and torques: [www.w-m-c.de](http://www.w-m-c.de).

- ➔ Please consult our technical service if your servo actuator is more than a year old. In this way you receive valid data.
- ➔ Please be sure to read the documentation provided by the manufacturer of the servo actuator.

### 3.2 Improper use

Any use transgressing the above-named restrictions (especially higher torques and speeds) is not compliant with the regulations, and is thus prohibited.

The operation of the servo actuator is prohibited if:

- It was not installed according to regulations (for example fastening bolts).
- The servo actuator is very dirty, damaged or blocked.
- It is operated without lubricant.
- The cables are damaged or improperly connected.
- The operating parameters have not been set properly.

### 3.3 Safety Instructions

The following symbols are used in this manual to warn you of hazards:



#### **DANGER!**

This symbol warns you of danger of injury to yourself and others.



#### **Attention**

This symbol warns you of the risk of damage to the servo actuator.



#### **Environment**

This symbol warns of environmental pollution risk.

#### 3.3.1 General safety instructions

##### Working on the servo actuator



#### **DANGER!**

Improperly executed work can lead to injury and damage.

- ➔ Always ensure that the servo actuator is only installed, maintained, and dismantled by trained technicians.

**DANGER!**

Current-flow through the body or arcing can lead to grave injury and death.

- Only perform tasks on the electrical system if you are:
  - A trained electrician.
  - A person trained in electro-technology, working under the supervision of a specialist electrician.
- Always adhere to the five safety rules for the de-energised state:
  - De-energise.
  - Secure against being turned on (for example by locking it).
  - Ensure that de-energised state exists.
  - Attach ground line and short-circuit the equipment.
  - Cover and safeguard any live parts in the immediate vicinity.

**DANGER!**

Impurities spinning through the air can cause grave injury.

- Before putting the servo actuator into operation, check that there are no impurities or tools near it.

**Maintenance****DANGER!**

An unintentional start of the machine during maintenance work can lead to serious accidents.

- Ensure that no one can start the machine while you are working on it.

**DANGER!**

Even only briefly running the machine during maintenance work can lead to accidents if the safety devices are not operating.

- Check that all safety devices have been mounted and are activated.

**Wiring****DANGER!**

Incorrect wiring can lead to injuries and damage.

- Only use power and signal cables recommended by WITTENSTEIN motion control.
- Do not cut off power and signal cables, and do not insert extensions.
- Make sure that the U-U, V-V and W-W motor phases are correctly connected.
- Make sure that the motor encoder interface of the servo controller is compatible to the servo actuator.
- Observe the prescribed voltage for the brakes (usually 24 V direct voltage) and the polarity.

## 4 Type plate information – identification

- ➔ The technical specifications can be found on your servo actuator's type plate according to the following scheme.

### 4.1 Identification plate, designation

The following specifications can be found on the identification plate:

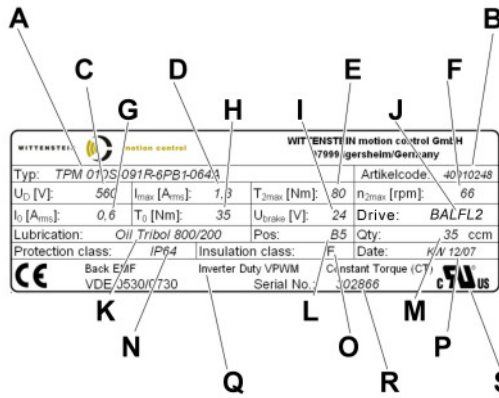

- A Ordering codes
- B Article code
- C Intermediate voltage
- D Maximum permitted current
- E Maximum moment of the gear output
- F Maximum gear output speed
- G Continuous stall current
- H Continuous stall moment at gear output
- I Brake voltage
- J For use with drive
- K Lubricant
- L Mounting position
- M Lubricant quantity
- N Type of protection
- O Insulation class
- P Date
- Q Specifications for UL approval
- R Series number
- S UL logo

Fig. 4.2

### Designation:

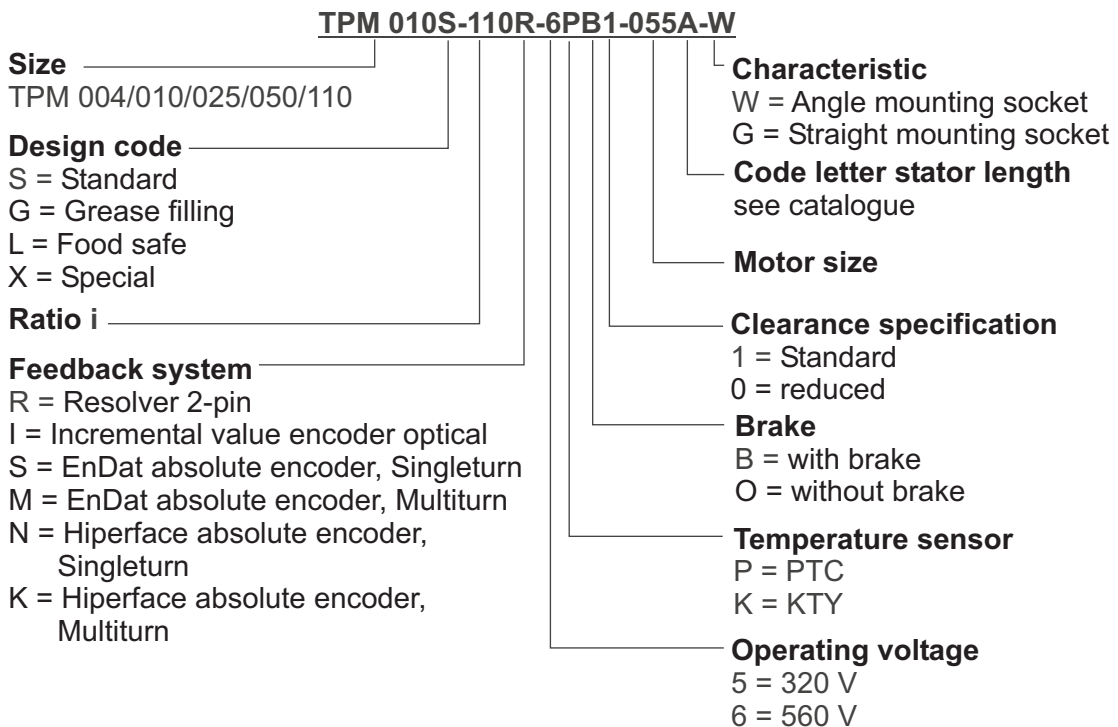

## 5 Setting the parameters

The tables in chapter 5 contain all of the parameters that are required for the initial start-up of a TPM<sup>+</sup> servo actuator from WITTENSTEIN motion control at a Danaher Motion Servostar 400. When the servo actuator and the servo drive are properly connected, these parameters guarantee that the servo actuator can be operated at idle with speed control. Based on these default settings, you can optimize the dynamics of the speed controller depending on the application.

Follow the details of the type plate.

Data for combinations not shown here are available on demand.

### 5.1 Adjustement of the current controller

The adjustement of the current controller with the parameter K<sub>p</sub> is acquired in addition of the recommended amplifier size of the Servostar 400. In the parameter tables the amplifier size is chosen by the maximum current of the servo actuator.

By use of other combinations the parameter K<sub>p</sub> can be calculated by the following formula:

$K_p = \text{DIPEAK (amplifier maximum current)} * 12 * \text{Inductance}_{\text{Lt\_Motor}} [\text{mH}] / 1000$

### 5.2 Selection of the motorfeedback, brake and commutation offset

For the selection of the motor feedback, the brake and the encoder offset the following inputs has to be done:

1. Open the screen Terminal in the Drive software
2. Depending on the motor feedback enter the following commands:  
 Resolver: „FBTYPE 0“  
                   „MRESPOLES 2“  
 Heidenhain EnDat: „FBTYPE 4“  
 Sick-Stegmann Hiperface: „FBTYPE 2“  
 After input of „FBTYPE <WERT>“, please confirm the message „Save to EEPROM and reset?“ with „YES“.
3. After the restart of the drive open the screen Terminal and enter the encoder offset with the command „MPHASE <OFFSET>“. Instead of <OFFSET> enter the appropriate value of the following parameter list.
4. In case of TPM<sup>+</sup> with brake enter the command „MBRAKE 1“ to activate the break control.
5. For TPM<sup>+</sup> with Resolver the entered data is stored in the amplifier with the input of the command „SAVE“.  
 For TPM<sup>+</sup> with EnDat the entered data is stored in the motor feedback with the input of the command „HSAVE“.  
 For TPM<sup>+</sup> with Hiperface the entered data is stored in the motor feedback with the input of the commands „HSAVE ERASE“ and „HSAVE“.
6. Restart the amplifier with the input of „COLDSTART“.

### 5.3 TPM<sup>+</sup> 560 V Ratio 16

Screen Page	Parameter	TPM 004S	TPM 010S	TPM 025S	TPM 050S	TPM 110S
	Stator Length	30	30	45	60	75
Feedback Resolver	Feedback type	Resolver	Resolver	Resolver	Resolver	Resolver
	No.of resolver poles	2	2	2	2	2
	Offset	90	90	270	270	270
	Resolver bandwidth	600	600	600	600	600
Feedback EnDat	Feedback type	EnDat	EnDat	EnDat	EnDat	EnDat
	Offset	90	90	90	90	90
Feedback Hiperface	Feedback type	Hiperface	Hiperface	Hiperface	Hiperface	Hiperface
	Offset	150	150	150	150	150
Speed	SpeedLimit [rpm]	6000	6000	6000	5000	5000
	Rotary Direction	Positive	Positive	Positive	Positive	Positive
	Overspeed [rpm]	6250	6250	6250	5250	5250
	Kp	0,2	0,25	0,3	0,4	0,5
	Tn [ms]	10	10	10	10	10
	PID-T2	0,2	0,2	0,2	0,2	0,2
	Feedback	0,6	0,6	0,6	0,6	0,6
Motor	Number / Name	0-NN	0-NN	0-NN	0-NN	0-NN
	No. of poles	8	8	12	12	12
	I0 [Arms]	1,00	1,20	5,60	13,40	16,30
	I0max [Arms]	3,20	5,20	17,00	40,00	70,00
	L [mH]	33,28	22,80	5,95	3,01	2,41
	Max. speed [rpm]	6000	6000	6000	5000	5000
	Brake	with / without	with / without	with / without	with / without	with / without
Current	Irms [Arms]	1,00	1,20	5,60	13,40	16,30
	Ipeak [Arms]	3,20	5,20	17,00	40,00	70,00
	Kp	2,40	1,64	0,57	0,29	0,23
	Tn [ms]	0,6	0,6	0,6	0,6	0,6
	Drive size KP calculation	443	443	446	446	446

Please consider chapter 5.1 for the tuning of the current controller

## 5.4 TPM<sup>+</sup> 560 V Ratio 21

Screen Page	Parameter	TPM 004S	TPM 010S	TPM 025S	TPM 050S	TPM 110S
	Stator Length	30	30	45	60	75
Feedback Resolver	Feedback type	Resolver	Resolver	Resolver	Resolver	Resolver
	No.of resolver poles	2	2	2	2	2
	Offset	90	90	270	270	270
	Resolver bandwidth	600	600	600	600	600
Feedback EnDat	Feedback type	EnDat	EnDat	EnDat	EnDat	EnDat
	Offset	90	90	90	90	90
Feedback Hiperface	Feedback type	Hiperface	Hiperface	Hiperface	Hiperface	Hiperface
	Offset	150	150	150	150	150
Speed	SpeedLimit [rpm]	6000	6000	6000	5000	5000
	Rotary Direction	Positive	Positive	Positive	Positive	Positive
	Overspeed [rpm]	6250	6250	6250	5250	5250
	Kp	0,2	0,25	0,3	0,4	0,5
	Tn [ms]	10	10	10	10	10
	PID-T2	0,2	0,2	0,2	0,2	0,2
	Feedback	0,6	0,6	0,6	0,6	0,6
Motor	Number / Name	0-NN	0-NN	0-NN	0-NN	0-NN
	No. of poles	8	8	12	12	12
	I0 [Arms]	1,00	1,20	5,60	12,20	16,30
	I0max [Arms]	2,60	5,20	17,00	34,50	70,00
	L [mH]	33,28	22,80	5,95	3,01	2,41
	Max. speed [rpm]	6000	6000	6000	5000	5000
	Brake	with / without	with / without	with / without	with / without	with / without
Current	Irms [Arms]	1,00	1,20	5,60	12,20	16,30
	Ipeak [Arms]	2,60	5,20	17,00	34,50	70,00
	Kp	2,40	1,64	0,57	0,29	0,23
	Tn [ms]	0,6	0,6	0,6	0,6	0,6
	Drive size KP calculation	443	443	446	446	446

Please consider chapter 5.1 for the tuning of the current controller

## 5.5 TPM<sup>+</sup> 560 V Ratio 31

Screen Page	Parameter	TPM 004S	TPM 010S	TPM 025S	TPM 050S	TPM 110S
	Stator Length	30	30	45	60	75
Feedback Resolver	Feedback type	Resolver	Resolver	Resolver	Resolver	Resolver
	No.of resolver poles	2	2	2	2	2
	Offset	90	90	270	270	270
	Resolver bandwidth	600	600	600	600	600
Feedback EnDat	Feedback type	EnDat	EnDat	EnDat	EnDat	EnDat
	Offset	90	90	90	90	90
Feedback Hiperface	Feedback type	Hiperface	Hiperface	Hiperface	Hiperface	Hiperface
	Offset	150	150	150	150	150
Speed	SpeedLimit [rpm]	6000	6000	6000	5000	5000
	Rotary Direction	Positive	Positive	Positive	Positive	Positive
	Overspeed [rpm]	6250	6250	6250	5250	5250
	Kp	0,2	0,25	0,3	0,4	0,5
	Tn [ms]	10	10	10	10	10
	PID-T2	0,2	0,2	0,2	0,2	0,2
	Feedback	0,6	0,6	0,6	0,6	0,6
Motor	Number / Name	0-NN	0-NN	0-NN	0-NN	0-NN
	No. of poles	8	8	12	12	12
	I0 [Arms]	1,00	1,20	5,60	13,40	16,30
	I0max [Arms]	2,20	4,70	14,30	29,80	70,00
	L [mH]	33,28	22,80	5,95	3,01	2,41
	Max. speed [rpm]	6000	6000	6000	5000	5000
	Brake	with / without	with / without	with / without	with / without	with / without
Current	Irms [Arms]	1,00	1,20	5,60	13,40	16,30
	Ipeak [Arms]	2,20	4,70	14,30	29,80	70,00
	Kp	2,40	1,64	0,57	0,29	0,23
	Tn [ms]	0,6	0,6	0,6	0,6	0,6
	Drive size KP calculation	443	443	446	446	446

Please consider chapter 5.1 for the tuning of the current controller

## 5.6 TPM<sup>+</sup> 560 V Ratio 61

Screen Page	Parameter	TPM 004S	TPM 010S	TPM 025S	TPM 050S	TPM 110S
	Stator Length	15	15	15	15	60
Feedback Resolver	Feedback type	Resolver	Resolver	Resolver	Resolver	Resolver
	No.of resolver poles	2	2	2	2	2
	Offset	90	90	270	270	270
	Resolver bandwidth	600	600	600	600	600
Feedback EnDat	Feedback type	EnDat	EnDat	EnDat	EnDat	EnDat
	Offset	90	90	90	90	90
Feedback Hiperface	Feedback type	Hiperface	Hiperface	Hiperface	Hiperface	Hiperface
	Offset	150	150	150	150	150
Speed	SpeedLimit [rpm]	6000	6000	6000	5000	5000
	Rotary Direction	Positive	Positive	Positive	Positive	Positive
	Overspeed [rpm]	6250	6250	6250	5250	5250
	Kp	0,2	0,25	0,3	0,4	0,5
	Tn [ms]	10	10	10	10	10
	PID-T2	0,2	0,2	0,2	0,2	0,2
	Feedback	0,6	0,6	0,6	0,6	0,6
Motor	Number / Name	0-NN	0-NN	0-NN	0-NN	0-NN
	No. of poles	8	8	12	12	12
	I0 [Arms]	0,70	0,90	1,80	3,50	12,90
	I0max [Arms]	1,30	2,20	5,90	12,00	30,40
	L [mH]	30,01	30,00	18,92	11,10	3,01
	Max. speed [rpm]	6000	6000	6000	5000	5000
	Brake	with / without	with / without	with / without	with / without	with / without
Current	Irms [Arms]	0,70	0,90	1,80	3,50	12,90
	Ipeak [Arms]	1,30	2,20	5,90	12,00	30,40
	Kp	2,16	2,16	1,36	1,07	0,29
	Tn [ms]	0,6	0,6	0,6	0,6	0,6
	Drive size KP calculation	443	443	443	446	446

Please consider chapter 5.1 for the tuning of the current controller

## 5.7 TPM<sup>+</sup> 560 V Ratio 64

Screen Page	Parameter	TPM 004S	TPM 010S	TPM 025S	TPM 050S	TPM 110S
	Stator Length	15	15	15	15	60
Feedback Resolver	Feedback type	Resolver	Resolver	Resolver	Resolver	Resolver
	No.of resolver poles	2	2	2	2	2
	Offset	90	90	270	270	270
	Resolver bandwidth	600	600	600	600	600
Feedback EnDat	Feedback type	EnDat	EnDat	EnDat	EnDat	EnDat
	Offset	90	90	90	90	90
Feedback Hiperface	Feedback type	Hiperface	Hiperface	Hiperface	Hiperface	Hiperface
	Offset	150	150	150	150	150
Speed	SpeedLimit [rpm]	6000	6000	6000	5000	5000
	Rotary Direction	Positive	Positive	Positive	Positive	Positive
	Overspeed [rpm]	6250	6250	6250	5250	5250
	Kp	0,2	0,25	0,3	0,4	0,5
	Tn [ms]	10	10	10	10	10
	PID-T2	0,2	0,2	0,2	0,2	0,2
	Feedback	0,6	0,6	0,6	0,6	0,6
Motor	Number / Name	0-NN	0-NN	0-NN	0-NN	0-NN
	No. of poles	8	8	12	12	12
	I0 [Arms]	0,80	0,90	1,80	3,50	12,80
	I0max [Arms]	1,30	2,10	5,60	12,00	28,70
	L [mH]	30,01	30,00	18,92	11,10	3,01
	Max. speed [rpm]	6000	6000	6000	5000	5000
	Brake	with / without	with / without	with / without	with / without	with / without
Current	Irms [Arms]	0,80	0,90	1,80	3,50	12,80
	Ipeak [Arms]	1,30	2,10	5,60	12,00	28,70
	Kp	2,16	2,16	1,36	1,07	0,29
	Tn [ms]	0,6	0,6	0,6	0,6	0,6
	Drive size KP calculation	443	443	443	446	446

Please consider chapter 5.1 for the tuning of the current controller

## 5.8 TPM<sup>+</sup> 560 V Ratio 91

Screen Page	Parameter	TPM 004S	TPM 010S	TPM 025S	TPM 050S	TPM 110S
	Stator Length	15	15	15	15	60
Feedback Resolver	Feedback type	Resolver	Resolver	Resolver	Resolver	Resolver
	No.of resolver poles	2	2	2	2	2
	Offset	90	90	270	270	270
	Resolver bandwidth	600	600	600	600	600
Feedback EnDat	Feedback type	EnDat	EnDat	EnDat	EnDat	EnDat
	Offset	90	90	90	90	90
Feedback Hiperface	Feedback type	Hiperface	Hiperface	Hiperface	Hiperface	Hiperface
	Offset	150	150	150	150	150
Speed	SpeedLimit [rpm]	6000	6000	6000	5000	5000
	Rotary Direction	Positive	Positive	Positive	Positive	Positive
	Overspeed [rpm]	6250	6250	6250	5250	5250
	Kp	0,2	0,25	0,3	0,4	0,5
	Tn [ms]	10	10	10	10	10
	PID-T2	0,2	0,2	0,2	0,2	0,2
	Feedback	0,6	0,6	0,6	0,6	0,6
Motor	Number / Name	0-NN	0-NN	0-NN	0-NN	0-NN
	No. of poles	8	8	12	12	12
	I0 [Arms]	0,50	0,70	1,50	3,20	9,00
	I0max [Arms]	0,90	1,40	3,80	8,70	18,80
	L [mH]	30,01	30,00	18,92	11,10	3,01
	Max. speed [rpm]	6000	6000	6000	5000	5000
	Brake	with / without	with / without	with / without	with / without	with / without
Current	Irms [Arms]	0,50	0,70	1,50	3,20	9,00
	Ipeak [Arms]	0,90	1,40	3,80	8,70	18,80
	Kp	2,16	2,16	1,36	0,80	0,29
	Tn [ms]	0,6	0,6	0,6	0,6	0,6
	Drive size KP calculation	443	443	443	443	446

Please consider chapter 5.1 for the tuning of the current controller

## 5.9 TPM<sup>+</sup> 320 V Ratio 16

Screen Page	Parameter	TPM 004S	TPM 010S	TPM 025S	TPM 050S	TPM 110S
	Stator length	30	30	45	60	75
Feedback Resolver	Feedback type	Resolver	Resolver	Resolver	Resolver	Resolver
	No. of resolver poles	2	2	2	2	2
	Offset	90	90	270	270	270
	Resolver bandwidth	600	600	600	600	600
Feedback EnDat	Feedback type	EnDat	EnDat	EnDat	EnDat	EnDat
	Offset	90	90	90	90	90
Feedback Hiperface	Feedback type	Hiperface	Hiperface	Hiperface	Hiperface	Hiperface
	Offset	150	150	150	150	150
Speed	SpeedLimit [rpm]	6000	6000	6000	5000	3700
	Rotary Direction	Positive	Positive	Positive	Positive	Positive
	Overspeed [rpm]	6250	6250	6250	5250	3950
	Kp	0,2	0,25	0,3	0,4	0,5
	Tn [ms]	10	10	10	10	10
	PID-T2	0,2	0,2	0,2	0,2	0,2
	Feedback	0,6	0,6	0,6	0,6	0,6
Motor	Number / Name	0-NN	0-NN	0-NN	0-NN	0-NN
	No. of poles	8	8	12	12	12
	I0 [Arms]	1,80	2,10	9,70	23,40	16,30
	I0max [Arms]	5,50	9,00	29,50	70,00	70,00
	L [mH]	11,10	7,10	1,98	1,00	2,41
	Max. speed [rpm]	6000	6000	6000	5000	3700
	Brake	with / without	with / without	with / without	with / without	with / without
Current	Irms [Arms]	1,80	2,10	9,70	23,40	16,30
	Ipeak [Arms]	5,50	9,00	29,50	70,00	70,00
	Kp	1,20	1,02	0,19	0,10	0,23
	Tn [ms]	0,6	0,6	0,6	0,6	0,6
	Drive size KP calculation	403/443	406/446	446	446	446

Please consider chapter 5.1 for the tuning of the current controller

## 5.10 TPM<sup>+</sup> 320 V Ratio 21

Screen Page	Parameter	TPM 004S	TPM 010S	TPM 025S	TPM 050S	TPM 110S
	Stator length	30	30	45	60	75
Feedback Resolver	Feedback type	Resolver	Resolver	Resolver	Resolver	Resolver
	No.of resolver poles	2	2	2	2	2
	Offset	90	90	270	270	270
	Resolver bandwidth	600	600	600	600	600
Feedback EnDat	Feedback type	EnDat	EnDat	EnDat	EnDat	EnDat
	Offset	90	90	90	90	90
Feedback Hiperface	Feedback type	Hiperface	Hiperface	Hiperface	Hiperface	Hiperface
	Offset	150	150	150	150	150
Speed	SpeedLimit [rpm]	6000	6000	6000	5000	3700
	Rotary Direction	Positive	Positive	Positive	Positive	Positive
	Overspeed [rpm]	6250	6250	6250	5250	3950
	Kp	0,2	0,25	0,3	0,4	0,5
	Tn [ms]	10	10	10	10	10
	PID-T2	0,2	0,2	0,2	0,2	0,2
	Feedback	0,6	0,6	0,6	0,6	0,6
Motor	Number / Name	0-NN	0-NN	0-NN	0-NN	0-NN
	No. of poles	8	8	12	12	12
	I0 [Arms]	1,80	2,10	9,70	21,30	16,30
	I0max [Arms]	4,60	9,00	29,50	60,30	70,00
	L [mH]	11,10	7,10	1,98	1,00	2,41
	Max. speed [rpm]	6000	6000	6000	5000	3700
	Brake	with / without	with / without	with / without	with / without	with / without
Current	Irms [Arms]	1,80	2,10	9,70	21,30	16,30
	Ipeak [Arms]	4,60	9,00	29,50	60,30	70,00
	Kp	1,20	1,02	0,19	0,10	0,23
	Tn [ms]	0,6	0,6	0,6	0,6	0,6
	Drive size KP calculation	403/443	406/446	446	446	446

Please consider chapter 5.1 for the tuning of the current controller

### 5.11 TPM<sup>+</sup> 320 V Ratio 31

Screen Page	Parameter	TPM 004S	TPM 010S	TPM 025S	TPM 050S	TPM 110S
	Stator length	30	30	45	60	75
Feedback Resolver	Feedback type	Resolver	Resolver	Resolver	Resolver	Resolver
	No. of resolver poles	2	2	2	2	2
	Offset	90	90	270	270	270
	Resolver bandwidth	600	600	600	600	600
Feedback EnDat	Feedback type	EnDat	EnDat	EnDat	EnDat	EnDat
	Offset	90	90	90	90	90
Feedback Hiperface	Feedback type	Hiperface	Hiperface	Hiperface	Hiperface	Hiperface
	Offset	150	150	150	150	150
Speed	SpeedLimit [rpm]	6000	6000	6000	5000	3700
	Rotary Direction	Positive	Positive	Positive	Positive	Positive
	Overspeed [rpm]	6250	6250	6250	5250	3950
	Kp	0,2	0,25	0,3	0,4	0,5
	Tn [ms]	10	10	10	10	10
	PID-T2	0,2	0,2	0,2	0,2	0,2
	Feedback	0,6	0,6	0,6	0,6	0,6
Motor	Number / Name	0-NN	0-NN	0-NN	0-NN	0-NN
	No. of poles	8	8	12	12	12
	I0 [Arms]	1,80	2,10	9,70	23,40	16,30
	I0max [Arms]	3,90	8,10	24,80	52,10	70,00
	L [mH]	11,10	7,10	1,98	1,00	2,41
	Max. speed [rpm]	6000	6000	6000	5000	3700
	Brake	with / without	with / without	with / without	with / without	with / without
Current	Irms [Arms]	1,80	2,10	9,70	23,40	16,30
	Ipeak [Arms]	3,90	8,10	24,80	52,10	70,00
	Kp	1,20	0,77	0,19	0,10	0,23
	Tn [ms]	0,6	0,6	0,6	0,6	0,6
	Drive size KP calculation	403/443	403/443	446	446	446

Please consider chapter 5.1 for the tuning of the current controller

## 5.12 TPM<sup>+</sup> 320 V Ratio 61

Screen Page	Parameter	TPM 004S	TPM 010S	TPM 025S	TPM 050S	TPM 110S
	Stator length	15	15	15	15	60
Feedback Resolver	Feedback type	Resolver	Resolver	Resolver	Resolver	Resolver
	No. of resolver poles	2	2	2	2	2
	Offset	90	90	270	270	270
	Resolver bandwidth	600	600	600	600	600
Feedback EnDat	Feedback type	EnDat	EnDat	EnDat	EnDat	EnDat
	Offset	90	90	90	90	90
Feedback Hiperface	Feedback type	Hiperface	Hiperface	Hiperface	Hiperface	Hiperface
	Offset	150	150	150	150	150
Speed	SpeedLimit [rpm]	6000	6000	6000	5000	5000
	Rotary Direction	Positive	Positive	Positive	Positive	Positive
	Overspeed [rpm]	6250	6250	6250	5250	5250
	Kp	0,2	0,25	0,3	0,4	0,5
	Tn [ms]	10	10	10	10	10
	PID-T2	0,2	0,2	0,2	0,2	0,2
	Feedback	0,6	0,6	0,6	0,6	0,6
Motor	Number / Name	0-NN	0-NN	0-NN	0-NN	0-NN
	No. of poles	8	8	12	12	12
	I0 [Arms]	1,20	1,50	3,20	6,40	22,50
	I0max [Arms]	2,40	3,80	10,20	20,80	53,10
	L [mH]	10,00	10,00	6,31	3,70	1,00
	Max. speed [rpm]	6000	6000	6000	5000	5000
	Brake	with / without	with / without	with / without	with / without	with / without
Current	Irms [Arms]	1,20	1,50	3,20	6,40	22,50
	Ipeak [Arms]	2,40	3,80	10,20	20,80	53,10
	Kp	1,08	1,08	0,91	0,36	0,10
	Tn [ms]	0,6	0,6	0,6	0,6	0,6
	Drive size KP calculation	403/443	403/443	406/446	446	446

Please consider chapter 5.1 for the tuning of the current controller

**5.13 TPM<sup>+</sup> 320 V Ratio 64**

Screen Page	Parameter	TPM 004S	TPM 010S	TPM 025S	TPM 050S	TPM 110S
	Stator length	15	15	15	15	60
Feedback Resolver	Feedback type	Resolver	Resolver	Resolver	Resolver	Resolver
	No. of resolver poles	2	2	2	2	2
	Offset	90	90	270	270	270
	Resolver bandwidth	600	600	600	600	600
Feedback EnDat	Feedback type	EnDat	EnDat	EnDat	EnDat	EnDat
	Offset	90	90	90	90	90
Feedback Hiperface	Feedback type	Hiperface	Hiperface	Hiperface	Hiperface	Hiperface
	Offset	150	150	150	150	150
Speed	SpeedLimit [rpm]	6000	6000	6000	5000	5000
	Rotary Direction	Positive	Positive	Positive	Positive	Positive
	Overspeed [rpm]	6250	6250	6250	5250	5250
	Kp	0,2	0,25	0,3	0,4	0,5
	Tn [ms]	10	10	10	10	10
	PID-T2	0,2	0,2	0,2	0,2	0,2
	Feedback	0,6	0,6	0,6	0,6	0,6
Motor	Number / Name	0-NN	0-NN	0-NN	0-NN	0-NN
	No. of poles	8	8	12	12	12
	I0 [Arms]	1,30	1,50	3,20	6,40	22,50
	I0max [Arms]	2,30	3,60	9,70	20,80	50,20
	L [mH]	10,00	10,00	6,31	3,70	1,00
	Max. speed [rpm]	6000	6000	6000	5000	5000
	Brake	with / without	with / without	with / without	with / without	with / without
Current	Irms [Arms]	1,30	1,50	3,20	6,40	22,50
	Ipeak [Arms]	2,30	3,60	9,70	20,80	50,20
	Kp	1,08	1,08	0,91	0,36	0,10
	Tn [ms]	0,6	0,6	0,6	0,6	0,6
	Drive size KP calculation	403/443	403/443	406/446	446	446

Please consider chapter 5.1 for the tuning of the current controller

### 5.14 TPM+ 320 V Ratio 91

Screen Page	Parameter	TPM 004S	TPM 010S	TPM 025S	TPM 050S	TPM 110S
	Stator length	15	15	15	15	60
Feedback Resolver	Feedback type	Resolver	Resolver	Resolver	Resolver	Resolver
	No.of resolver poles	2	2	2	2	2
	Offset	90	90	270	270	270
	Resolver bandwidth	600	600	600	600	600
Feedback EnDat	Feedback type	EnDat	EnDat	EnDat	EnDat	EnDat
	Offset	90	90	90	90	90
Feedback Hiperface	Feedback type	Hiperface	Hiperface	Hiperface	Hiperface	Hiperface
	Offset	150	150	150	150	150
Speed	SpeedLimit [rpm]	6000	6000	6000	5000	5000
	Rotary Direction	Positive	Positive	Positive	Positive	Positive
	Overspeed [rpm]	6250	6250	6250	5250	5250
	Kp	0,2	0,25	0,3	0,4	0,5
	Tn [ms]	10	10	10	10	10
	PID-T2	0,2	0,2	0,2	0,2	0,2
	Feedback	0,6	0,6	0,6	0,6	0,6
Motor	Number / Name	0-NN	0-NN	0-NN	0-NN	0-NN
	No. of poles	8	8	12	12	12
	I0 [Arms]	0,90	1,30	2,60	5,60	15,80
	I0max [Arms]	1,60	2,40	6,50	15,00	32,90
	L [mH]	10,00	10,00	6,31	3,70	1,00
	Max. speed [rpm]	6000	6000	6000	5000	5000
	Brake	with / without	with / without	with / without	with / without	with / without
Current	Irms [Arms]	0,90	1,30	2,60	5,60	15,80
	Ipeak [Arms]	1,60	2,40	6,50	15,00	32,90
	Kp	1,08	1,08	0,68	0,36	0,10
	Tn [ms]	0,6	0,6	0,6	0,6	0,6
	Drive size KP calculation	403/443	403/443	403/443	446	446

Please consider chapter 5.1 for the tuning of the current controller

## 6 Connection schematic TPM<sup>+</sup>

- ➔ Detailed information on cable design and the type of shielding can be found in the documentation from the servo drive manufacturer.

### 6.1 TPM<sup>+</sup> with resolver

WITTENSTEIN motion control offers pre-manufactured and drag chain compatible cablesets for this servo drive. Please take the required order informations from the TPM+ catalogue.

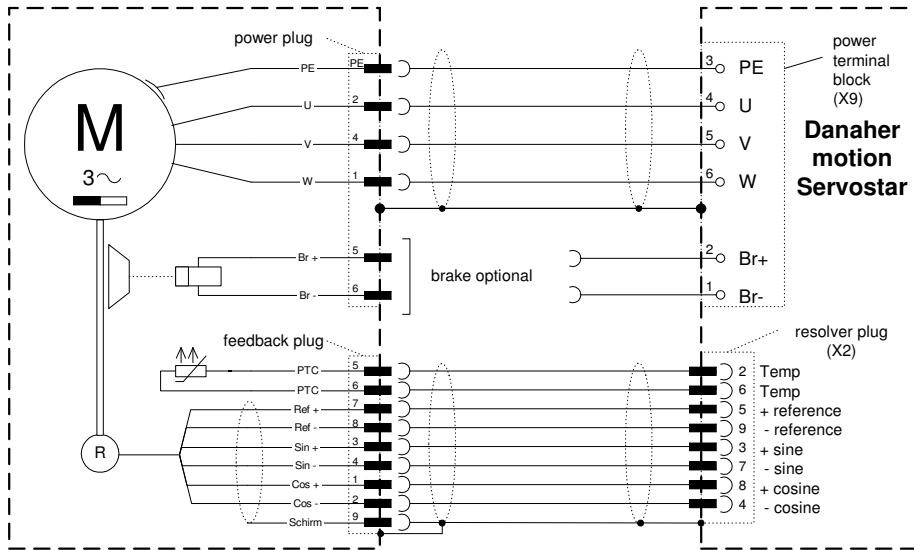

**6.2 TPM+ with absolute encoder Heidenhain EnDat ECN1113 / EQN 1125**

WITTENSTEIN motion control offers pre-manufactured and drag chain compatible cables for this servo drive. Please take the required order information from the TPM+ catalogue.

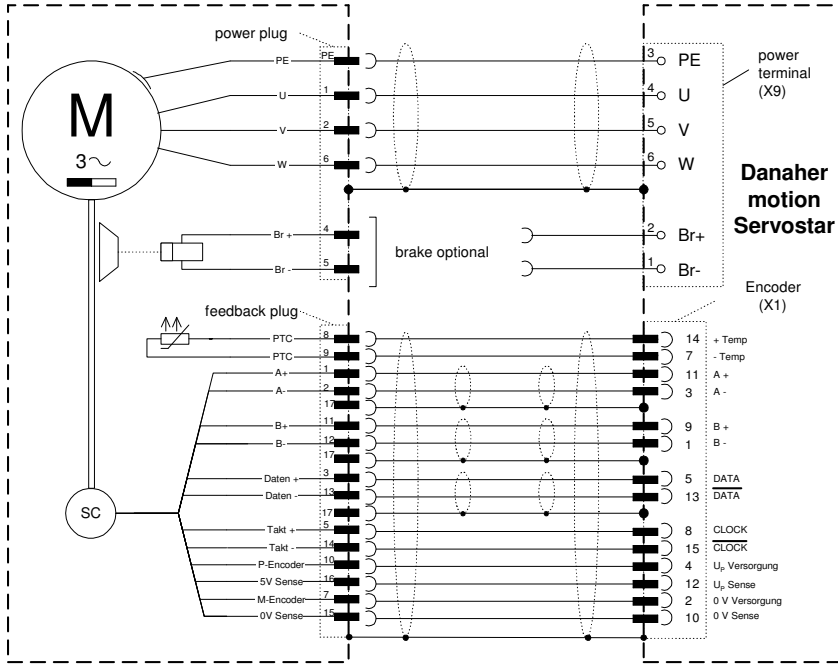

**6.3 TPM+ with absolute encoder Sick-Stegmann SKS36 / SKM36**

WITTENSTEIN motion control offers pre-manufactured and drag chain compatible cables for this servo drive. Please take the required order information from the TPM+ catalogue.

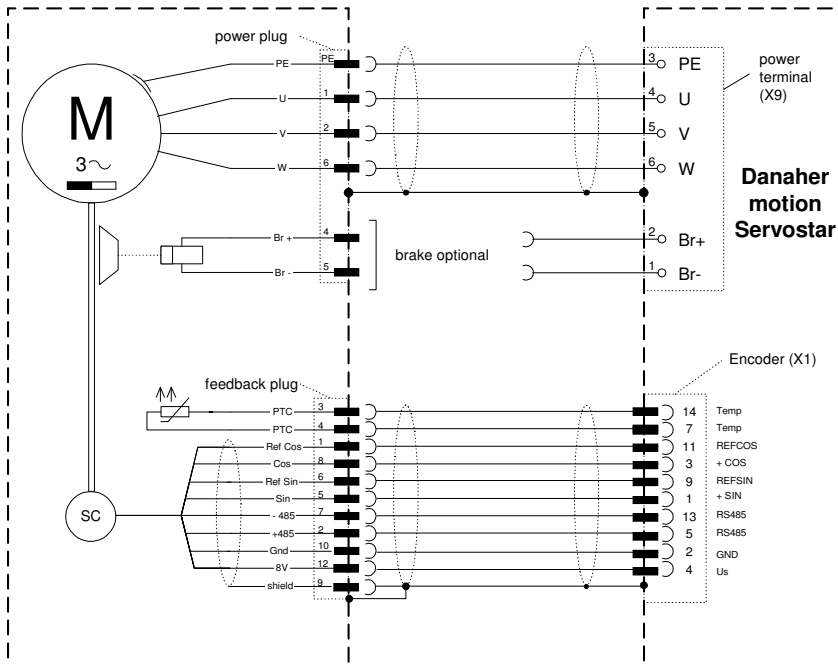



motion control

WITTENSTEIN motion control GmbH  
Walter-Wittenstein-Straße 1  
97999 Igersheim

**WITTENSTEIN - being one with the future**

**[www.wittenstein.de](http://www.wittenstein.de)**